

PUMPMASTER 35 - 8:1 RATIO OIL PUMP



HEAVY-DUTY HIGH PRESSURE PUMP

535 830

Double acting air operated high pressure and reliable delivery pump for oil distribution applications. Built in port for optional (PN 609 008) pressure relief valve.

FLUIDS HANDLED

- Synthetic and mineral based oil.
- Hydraulic oil.
- Gear lube.
- Transmission fluid.
- Corrosion protection fluids.

MARKETS SERVED

- Vehicle maintenance centres.
- Fleet service.
- Mining and construction.
- Lube trucks.
- Railroad and mass transit maintenance.
- Marine.
- In-plant.

MODELS

PART No.	APPLICATION	PUMP TUBE HEIGHT	TOTAL HEIGHT	WEIGHT
535 830	Universal stub pump with bung adaptor	200 mm	487 mm	6.8 kg
535 880	Universal stub pump	200 mm	487 mm	6.4 kg
535 810	205 l (55 gal) drum bung mounted	925 mm	1,212 mm	8.3 kg

TECHNICAL DATA

Pump pressure ratio	8:1
Air pressure operating range	2 to 12 bar (30 to 175 psi)
Air consumption (1)	350 NI/min (12.4 scfm)
Maximum fluid outlet pressure	96 bar (1,400 psi)
Air motor effective diameter	80 mm (3.15")
Air motor stroke	80 mm (3.15")
Delivery at 80 cpm	7 l/min (1.9 gal/min)
Maximum free flow delivery	17 l/min (4.5 gal/min)
Air inlet	3/8" BSP (F)
Fluid inlet	1" BSP (F)
Fluid outlet	1/2" BSP (F)
Wetted and seal materials	Cast iron / Hard chromed steel / Steel / Polyurethane, NBR
Noise level (2)	80 dB

(1) Maximum air consumption with 5 psi (72 bar) air inlet pressure and 80 cpm.

(2) Maximum noise level measured at 3' (1 m) from the pump, 100 psi (7 bar) air pressure and free delivery.



DIMENSIONS mm

MODEL	535 830	535 880	535 810
A	487	487	1,212
B	287	287	287
C	42	42	42
D	200	200	925

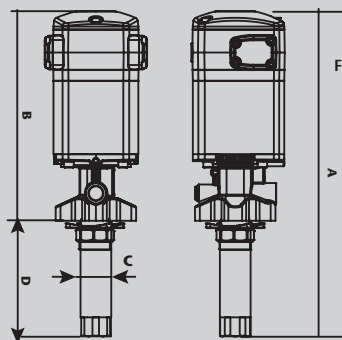
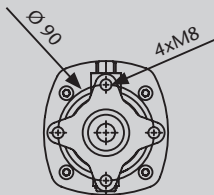

SAE 10, 21 °C (70 °F) CAPACITY CURVE

