

PUMPMASTER 45 - 10:1 RATIO OIL PUMPS



HEAVY-DUTY HIGH FLOW PUMPS

536 010

Double acting air operated moderate pressure pump for very large oil systems or when a low air pressure or cold temperatures would limit pump performance. Built in port for optional pressure relief valve (PN 609 007). Flange mounted pumps. Pump 536 010 can also use bung adaptor (PN 360 006) for bung mounting.

PRODUCTS HANDLED

- Synthetic and mineral based lubricants.
- Hydraulic oil.
- Gear oil.
- Transmission fluid.

MARKETS

- Large auto and truck dealers.
- Construction equipment maintenance.
- Mining equipment maintenance.
- Railroad and mass transit maintenance.
- Large fleets.
- Lube trucks.
- Marine.
- In plant oil distribution.



MODELS

PART No.	APPLICATION	PUMP TUBE HEIGHT	TOTAL HEIGHT	WEIGHT
536 030	Universal stub pump	200 mm	702 mm	16.5 kg
536 010	205 l (55 gal) drum bung mounted	855 mm	17 kg	

TECHNICAL DATA

Pump pressure ratio	10:1
Air pressure operating range	1.5 to 12 bar (20 to 170 psi)
Air consumption ⁽¹⁾	850 NI/min (30 cfm)
Maximum fluid outlet pressure	120 bar (1,700 psi)
Air motor effective diameter	115 mm (4 1/2")
Air motor stroke	100 mm (4")
Delivery at 80 cycles/min.	15 l/min (4 gal/min)
Maximum free flow delivery	65 l/min (17.17 gal/min)
Air inlet	1/2" BSP (F)
Fluid inlet	1 1/2" BSP (F)
Fluid outlet	3/4" BSP (F)
Wetted and seal materials	Cast iron / Hard chromed steel / Steel / Polyurethane / NBR
Noise level ⁽²⁾	80 dB

(1) Maximum air consumption with 5 bar air inlet pressure and 80 cycles/min.

(2) Maximum noise level measured at 1 m from the pump, 7 bar air pressure and free delivery.

SAE 10, 21 °C (70 °F) CAPACITY

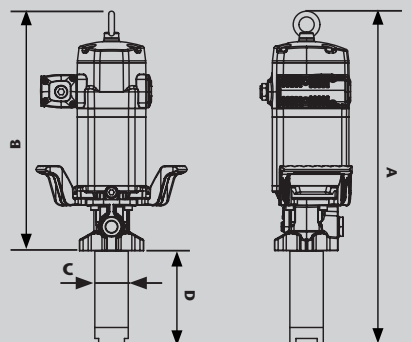
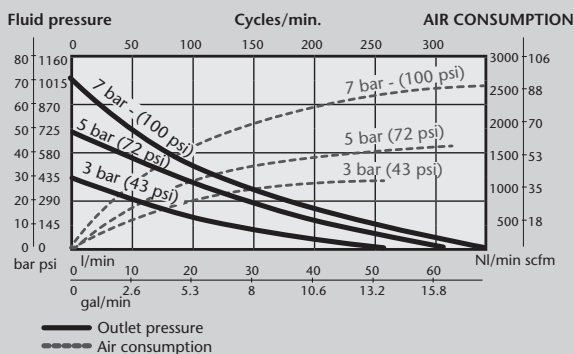

DIMENSIONS (mm)

MODEL	536 030	536 010
A	702	1,357
B	502	502
C	54	54
D	200	855

