

PUMPMASTER 60 - 6:1 RATIO OIL PUMP

537 630

HEAVY-DUTY HIGH DELIVERY PUMP

Double acting air operated medium pressure and high delivery pump, for large installations with simultaneous operation outlets and applications that require large, constant delivery rates. Built in port for optional pressure relief valve (PN 609 007). Flange mounted pump.



PRODUCTS HANDLED

- Synthetic and mineral based lubricants.
- Hydraulic oil.
- Gear oil.
- Transmission fluid.

MARKETS

- Very large auto and truck dealers.
- Construction equipment maintenance.
- Mining equipment maintenance.
- Large fleets.
- Railroad and mass transit maintenance.
- Marine.
- In plant oil distribution.

MODELS

PART No.	APPLICATION	PUMP TUBE HEIGHT	TOTAL HEIGHT	WEIGHT
537 630	Universal stub pump	200 mm	716 mm	19 kg

TECHNICAL DATA

Pump pressure ratio	6:1
Air pressure operating range	1.5 to 12 bar (20 to 170 psi)
Air consumption ⁽¹⁾	1,100 NI (39 cfm)
Maximum fluid outlet pressure	72 bar (1,020 psi)
Air motor effective diameter	150 mm (6")
Air motor stroke	100 mm (4")
Delivery at 60 cycles/min.	35 l/min (9.25 gal/min)
Maximum free flow delivery	100 l/min (26.42 gal/min)
Air inlet	1/2" BSP (F)
Fluid inlet	1 1/2" BSP (F)
Fluid outlet	3/4" BSP (F)
Wetted and seal materials	Cast iron / Aluminium / Nickel / Steel / Polyurethane / NBR
Noise level ⁽²⁾	80 dB

(1) Maximum air consumption with 5 bar air inlet pressure and 60 cycles/min.

(2) Maximum noise level measured at 1 m from the pump, 7 bar air pressure and free delivery.

DIMENSIONS (mm)

MODEL	537 630
A	716
B	516
C	90
D	200

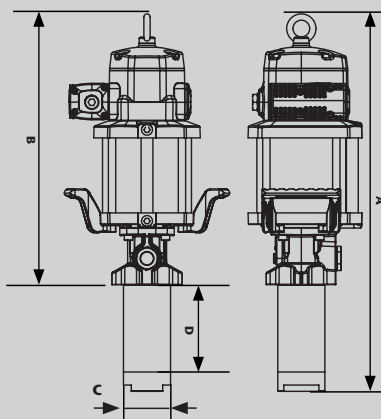

SAE 10, 21 °C (70 °F) CAPACITY

