

505 224

15 AND 20 METERS MAXIMUM HOSE CAPACITY

**Full metal, Intensive Duty double pedestal hose reels with hose capacity up to 15 m x 3/4" and 20 m x 1/2" hose.**

**FLUIDS HANDLED**

- Air.
- Water.
- Antifreeze and windshield wash solutions.
- Synthetic and mineral oils.
- AdBlue®/DEF.
- Waste Oil Evacuation.
- Diesel.
- Grease.

**MARKETS / APPLICATIONS**

- Truck dealers.
- Service shops.
- Fleets.
- Lube trucks.
- Mining and construction.
- Railroad and mass transit.
- General manufacturing.

**MOUNTING**

- Floor.
- Wall.
- Ceiling.
- Tank.

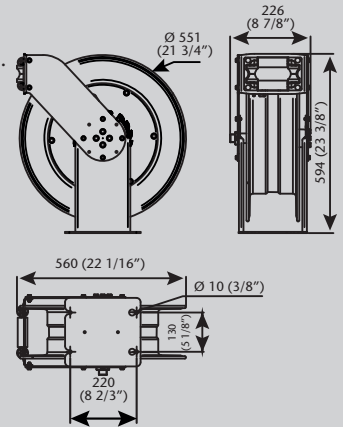

Dimensions mm (inches)



- Very tough construction able to stand regular use and abuse in Intensive Duty applications.
- Fatigue resistant steel spring for years of durable performance and even load when pulling and recoiling the hose.
- Full port shaft and swivel for no restrictions.
- Spool mounted on two permanent lubricated and sealed ball bearings to reduce torque load on spring for smooth retraction and longer life.
- Large effective radial latching area for easier operation.
- Hose guide arm can be placed in different positions to accommodate any method of mounting.
- Narrow footprint allows accommodating more reels on the same surface.
- Hose reels with hose include 0.8 m inlet hose.

PART No.	BARE REEL	HOSE IN Ø	HOSE LENGTH	CONNECTING HOSE INLET	DELIVERY HOSE OUTLET	PRESSURE RATING	WEIGHT (With hose)
<b>AIR - WATER - ANTIFREEZE SOLUTIONS - DIESEL - LUBRICANTS</b>							
<b>505 232</b>	<b>505 932</b>	1/2"	20 m	3/4" BSP (F)	1/2" BSP (M)	160 bar	36 kg
<b>505 224</b>	<b>505 924</b>	3/4"	15 m	3/4" BSP (M)	3/4" BSP (M)	125 bar	38 kg
<b>AdBlue®/DEF - WINDSHIELD WASH SOLUTIONS - WASHING SOLUTIONS</b>							
<b>505 524</b>	<b>505 529</b>	3/4"	15 m	3/4" BSP (F)	3/4" BSP (F)	20 bar	39 kg
<b>GREASE AND HYDRAULIC FLUID</b>							
<b>505 332</b>	<b>505 339</b>	1/2"	20 m	1/2" BSP (M)	1/2" BSP (M)	400 bar	39 kg

05 HOSE REELS