

DF30 POLYPROPYLENE DIAPHRAGM PUMPS. 38 L/MIN

553 164 / 553 124

Very compact and reliable polypropylene diaphragm pumps for medium to small volume transfer (38 l/min max.), dosing, spraying and dispensing a variety of fluids.

Typical applications are transferring and dispensing windshield wash and antifreeze solutions, pure windshield wash and AdBlue®/DEF. ATEX approved pumps are available for use in potential explosive environments and with flammable fluids, like pure ethanol.

They can be used as stand-alone pumps for transfer applications or as systems pumps in small distribution systems that include hose reels.

Pumps with dual inlet are available for 1:1 ratio mixing of fluids with similar viscosities, like windshield wash or antifreeze with water. All dual inlet pumps have 2 x 3/8" BSP (F) inlet.



03

OTHER FLUIDS PUMPS

FLUIDS HANDLED

- Antifreeze and antifreeze solutions
- Windshield wash and wind shield wash solutions
- Detergents
- AdBlue®/DEF
- Pure windshield wash and ethanol

MARKETS SERVED

- Service shops
- Car and truck dealers
- In plant
- Agriculture

MODELS						
PART No.	PUMP BODY	DIAPHRAGMS	BALLS	SEATS	OTHER WETTED MATERIAL	APPLICATIONS
553 164	Polypropylene	Hytrel®	Hytrel®	Stainless steel	Viton®	Antifreeze and windshield wash solutions, AdBlue®/DEF
553 162	Conductive Polypropylene	PTFE	PTFE	Stainless steel	Viton®	ⒺⒻ ATEX pump for pure ethanol, pure windshield wash, detergents
553 124	Polypropylene Dual inlet body	Hytrel®	PTFE	Stainless steel	Viton®	1:1 ratio water/windshield or antifreeze solutions

Tested at room temperature, with water and flooded pump with 800 mm (31.5 inches) height of water above the pump inlet.

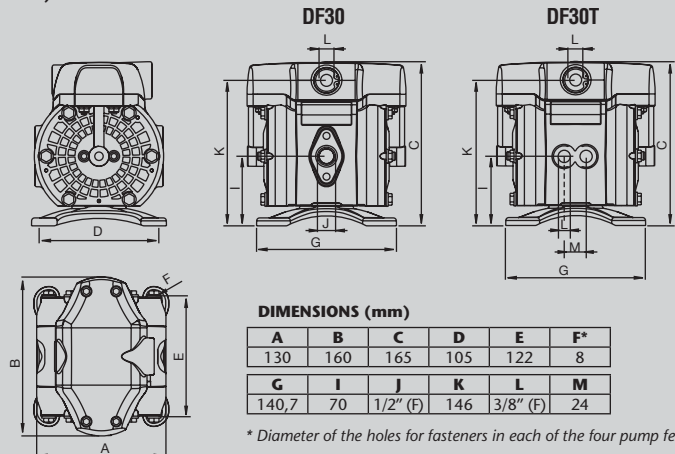
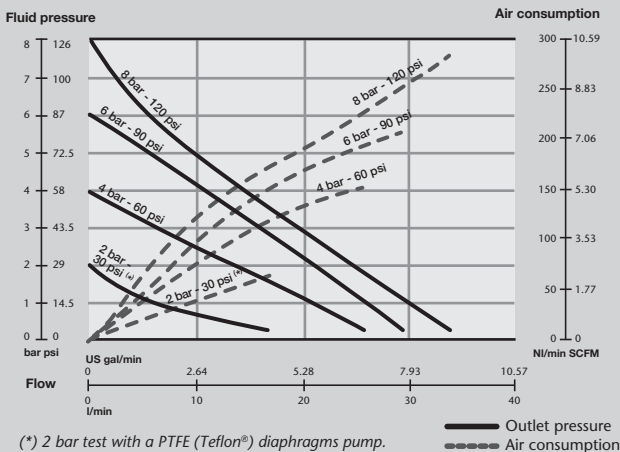

* Diameter of the holes for fasteners in each of the four pump feet.