

ENCLOSED HOSE REEL 507 SERIES FOR WINDSHIELD, WINDSHIELD WASH SOLUTIONS, AD-BLUE® - DEF, DETERGENTS
 ENROLLADOR CARENADO SERIE 507 PARA SOLUCIONES ACUOSAS, LAVADO, UREA Y DESENGRASANTES
 ENROULEUR DE TUYAU AVEC CARÉNAGE SÉRIE 507 SOLUTIONS DE LAVAGE DE PARE-BRISE, AD-BLUE® DEF, DÉTERGENTS
 VERKLEIDETER SCHLAUCHAUFROLLER SERIE 507 SCHEIBENWASCHANLAGEN, AD-BLUE®, REINIGUNGSMITTEL

507762
507782

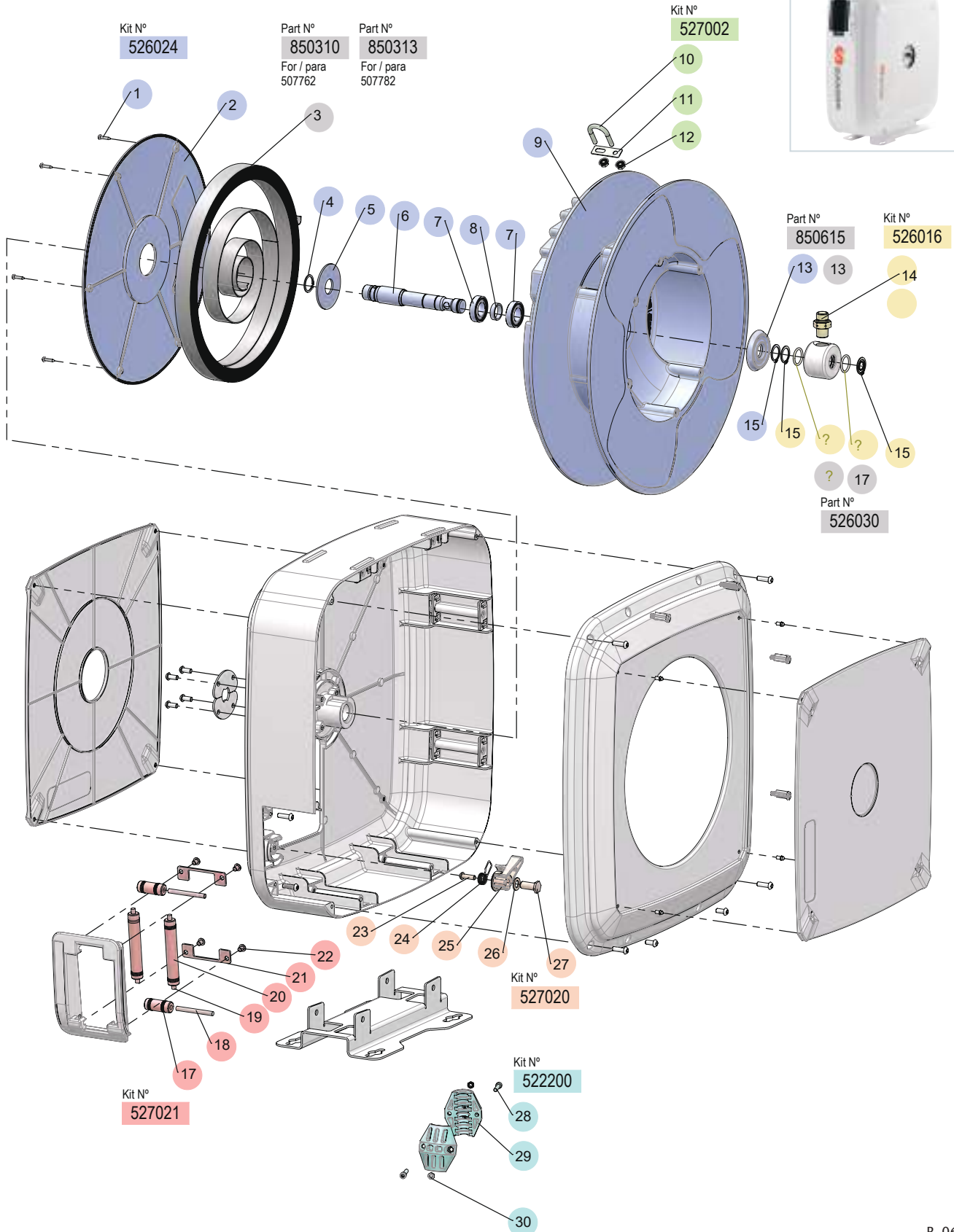

2023_06_27-12:30

R. 06/23

SPARE PARTS KITS / KITS DE RECAMBIO / KITS DE REMPLACEMENT / AUSTAUSCHKITS

Part No. / Cód. / Réf. / Art. Nr.:

ENCLOSED HOSE REEL 507 SERIES FOR WINDSHIELD, WINDSHIELD WASH SOLUTIONS, AD-BLUE® - DEF, DETERGENTS
 ENROLLADOR CARENADO SERIE 507 PARA SOLUCIONES ACUOSAS, LAVADO, UREA Y DESENGRASANTES
 ENROULEUR DE TUYAU AVEC CARÉNAGE SÉRIE 507 SOLUTIONS DE LAVAGE DE PARE-BRISE, AD-BLUE® DEF, DÉTERGENTS
 VERKLEIDETER SCHLAUCHAUFRÖLLER SERIE 507 SCHEIBENWASCHANLAGEN, AD-BLUE®, REINIGUNGSMITTEL

507762
507782
SPARE PARTS KITS / KITS DE RECAMBIO / KITS DE REMPLACEMENT / AUSTAUSCHKITS

Part No. Cód. Réf. Art. Nr.	Incl. Pos.	Description	Descripción	Description	Beschreibung	Remarks Observaciones Remarques Bemerkungen
522200	2x(29), 2x(30), 2x(31)	Hose Stopper Assembly	Kit Tope Manguera	Kit d'Arrêt de Tuyau	Schlauchan-Schlag- satz	-
526016	14, 15, 2x(16), 2x(17)	Swivel Assembly	Kit Conjunto Rótula	Kit Rotule	Kugelgelenk-Kit	-
526024	6x(1), 2, 4, 5, 6, 2x(7), 8, 9, 13, 16	Spool + Shaft	Kit Disco + Eje	Kit Tambour + Axe	Gehäuse + Achse Kit	-
527002	10, 11, 2x(12)	U-Bolt Assembly	Kit Abarcón	Bride de Fixation	P-Clip Kit	-
527020	24, 25, 26, 27, 28	Ratchet Assembly	Kit Conjunto Trinquete	Kit de Montage du Cliquet	Ratschen-Bausatz	-
527021	2x(18), 2x(19), 4x(20), 2x(21), 2x(22), 2x(23)	Roller Outlet Assembly	Kit Salida Manguera	Kit Sortie de Tuyau	Schlauchauslass Kit	-

**PARTS AVAILABLE SEPARATELY / PIEZAS DISPONIBLES POR SEPARADO /
 PIÈCES DISPONIBLES SÉPARÉMENT / TEILE SEPARAT ERHÄLTICH**

Part No. Cód. Réf. Art. Nr.	Incl. Pos.	Description	Descripción	Description	Beschreibung	Remarks Observaciones Remarques Bemerkungen
526030	2x(17)	Swivel O-Rings	Juntas de Rótula	Joints Toriques pour Rotule	Drehgelenk O-Ringe	-
850310	3	Power Spring	Resorte	Ressort	Feder	For/para/pour/ Für: 507762
850313	3	Power Spring	Resorte	Ressort	Feder	For/para/pour/ Für: 507782
850615	13	Spool Washer	Arandela Disco	Rondelle	Unterlegscheibe	-

**HOSES INFORMATION / INFORMACIÓN DE LAS MANGUERAS
 INFORMATIONS SUR LES TUYAUX / SCHLAUCH-INFORMATIONEN**

Part No. Cód. Réf. Art. Nr.	Inlet Part. No. Cód. Manguera Acometida / Réf. Tuyau d'Entrée / Art. Nr. Ansaugschlauch	Inlet Data Datos Manguera de Acometida Données Tuyau d'Alimentation Daten Versorgungsschlauch	Outlet Part. No. Cód. Manguera de Servicio / Réf. Tuyau de Service / Daten zum Serviceschlauch	Outlet Data Datos Manguera de Servicio Données du Tuyau de Service Daten zum Serviceschlauch
507762	750380	1/2" BSP (F) x 825 mm (32.5") - 20 bar (290 psi)	750381	1/2" BSP (F) x 10075 mm (30') - 20 bar (290 psi)
507782	750380	1/2" BSP (F) x 825 mm (32.5") - 20 bar (290 psi)	750382	1/2" BSP (F) x 15075 mm (50') - 20 bar (290 psi)

R. 06/23